

Twinfix Thermoclick Installation Guidelines

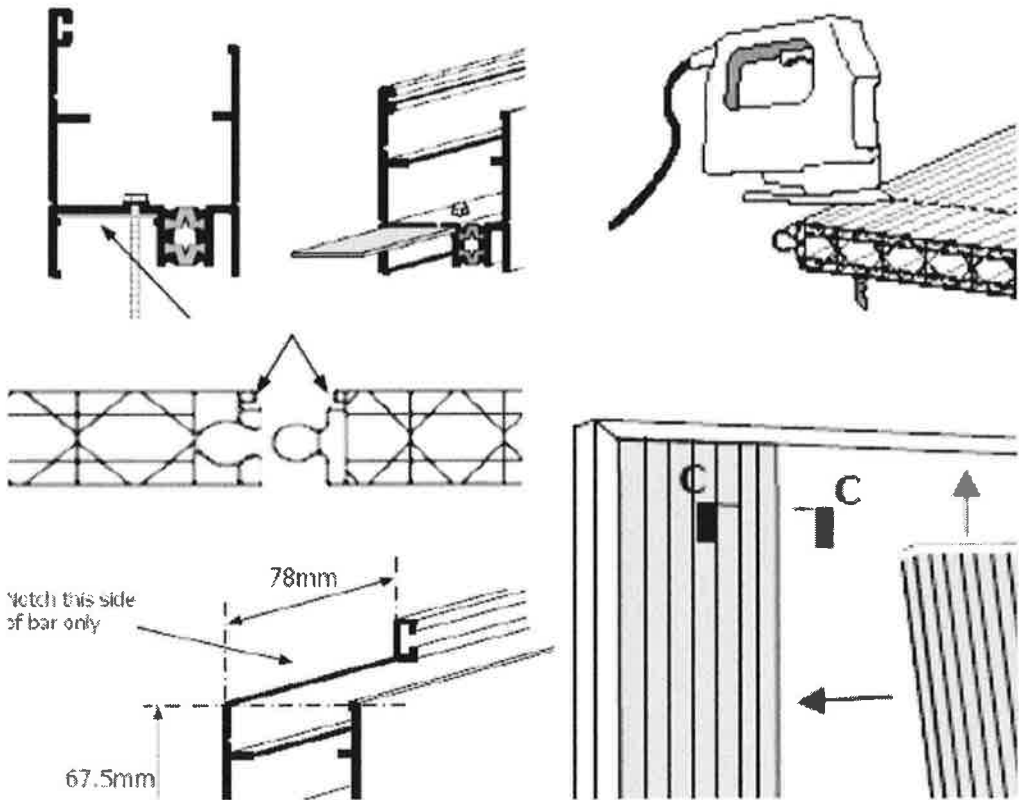

FIXING THE ALUMINIUM FRAME (1)

Thermoclick frame profiles can be fixed directly to steelwork and other substrates that are straight and true. Otherwise use shims to pack out where necessary.

BASE RAIL:-

Fix at maximum 500mm centres using stainless steel screws with bonded washers. Allow a gap of approx 2mm between lengths of base rail.

Joint Plates are supplied to assist in lining up adjacent lengths of profile.

Insert a 28 x 100mm joint plate at each base bar joint, securing with a fixing screw one side of joint only.

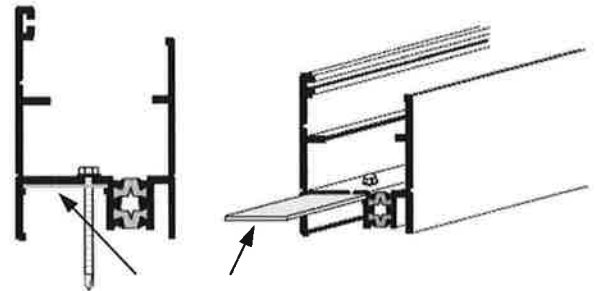

Joint Plate
28mm x 100mm

TOP / SIDE RAILS:-

Fix at maximum 500mm centres using stainless steel screws (bonded washers not required). Allow a gap of approx 2mm between lengths of top/side rail.

Joint Plates are supplied to assist in lining up adjacent lengths of profile.

Insert a 32 x 100mm joint plate at each base rail joint, securing with a fixing screw one side of joint only.

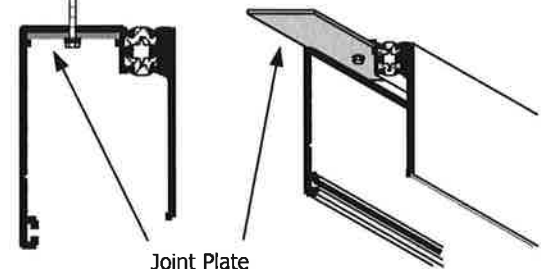

Joint Plate
32mm x 100mm

Typical Base Rail Fixing:-

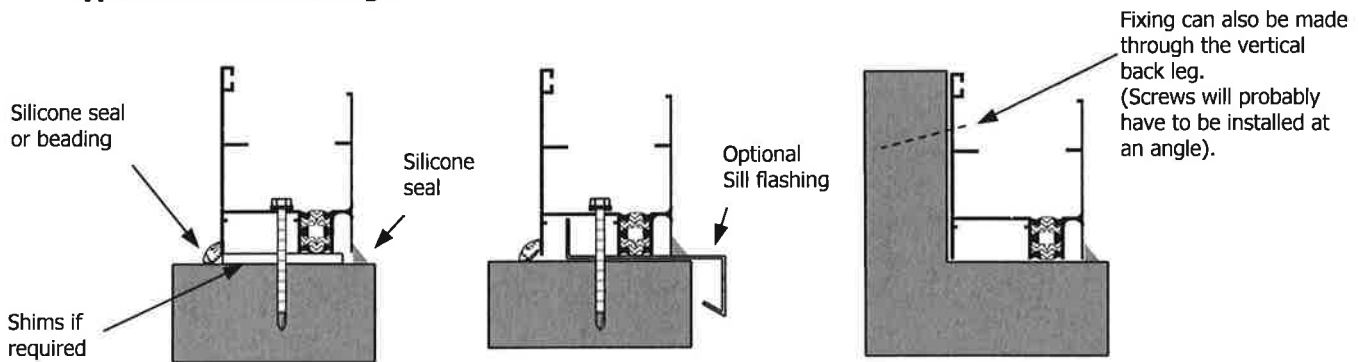

THE CORNERS:-

90° Corners are most easily formed using pre-welded corner pieces.

NB. Supplied as a set of 4 pieces.
2No Top corners (which can be rotated)
1No LH Base corner
1No RH Base corner

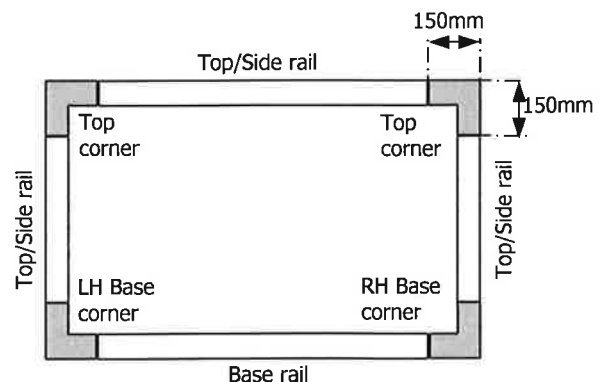

FIXING THE ALUMINIUM FRAME (2)

Corners can also be formed on site by either mitre cutting or square cutting the rails.

NB. Site cut corners may need to be sealed with silicone.



Depending upon detailing, site cut mitres can sometimes be secured using a small rivet-fixed aluminium angle. (A joint plate could possibly be bent to do this job).

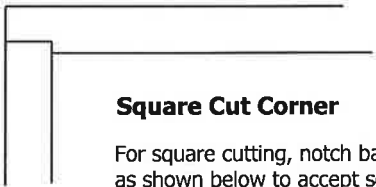
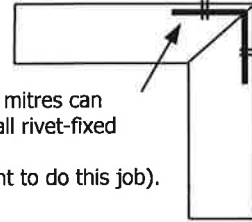

For square cutting, notch base & top rails as shown below to accept square cut ends of vertical side rail.

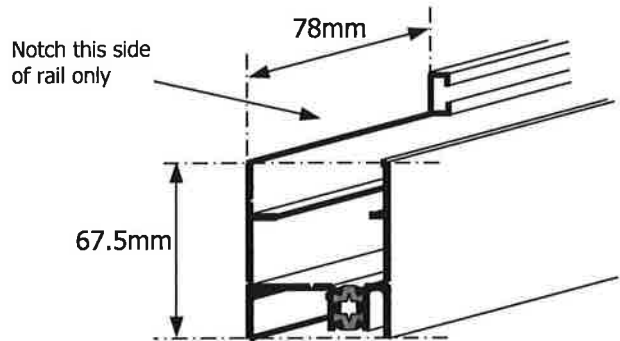

COMPLETING THE ALUMINIUM FRAME

Clean any dirt & swarf etc out of the profiles

Seal and drill base rails.

(Top & side bars do not require drilling or sealing)

Seal inside base rail joints and at each end of a glazing run using a silicone sealant.

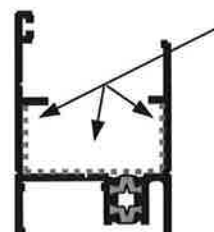

Sealant in lower drainage channel

NB. Ensure that the base rail corners are both sealed.

Base rail only:-

Drill drainage holes at 'A' or 'B' (Whichever is to the outside of the building).

A 'V' groove in the face of the base rail indicates where 5mm Diameter drainage holes at maximum 500mm centres are to be drilled on site in the base rails at 'A' or 'B'. There must be at least one hole in any individual length of rail. These holes must drain to the outside of the building.

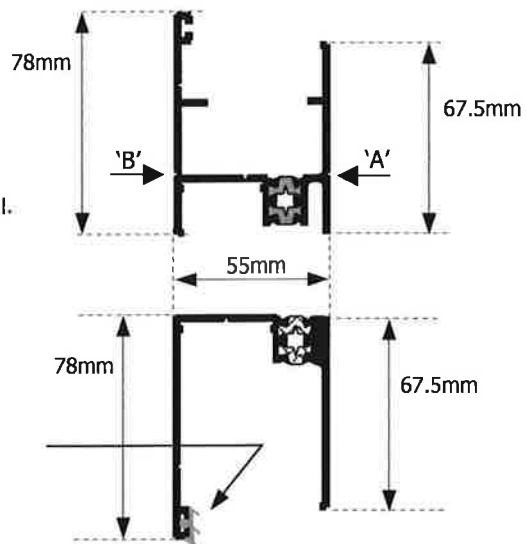

All rails:-

Insert 'E' Gasket into all the profiles.

'E' Gasket is fitted into a groove in the longest leg of the rails. Take care not to stretch the gasket as it is being inserted. Mitre cut the gasket at corners.

INSTALLING THE POLYCARBONATE PANELS (1)

Important!!

The UV protected side of Thermoclick panels must always be to the outside of the building. The correct side is shown on the removable surface film and can also be established by reference to the panel joints.

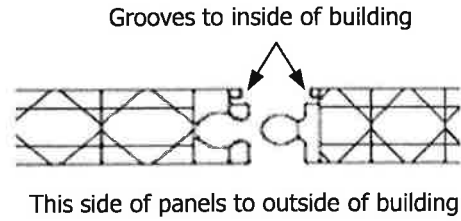

Panels can be installed Left to Right or Right to Left.

If there is intermediate structure, installing the panels "tongue first" allows easier fixing of the "Fix-Keys".

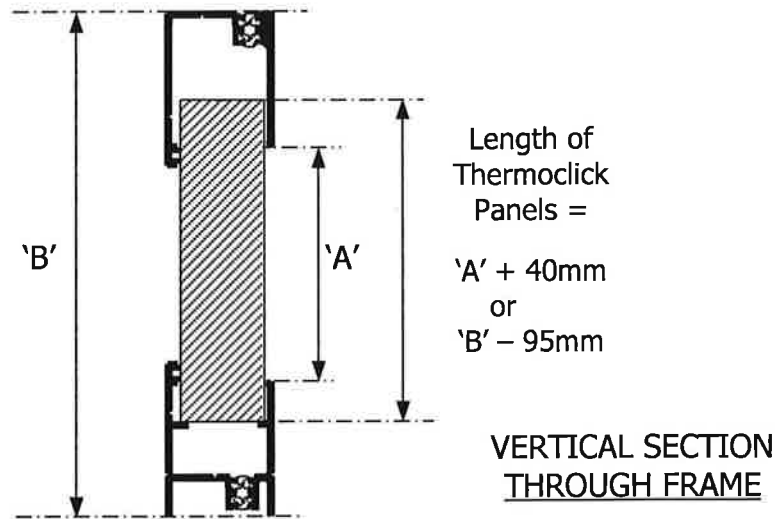

PREPARE THERMOCLICK PANELS:-

- 1 Cut Thermoclick panels to length using a fine toothed saw.
(Internal vertical frame dimension + 40mm or Overall frame height - 95mm).
- 2 Blow dust and swarf out of the panels.
- 3 Apply adhesive tapes to top and foot of panels.
Impermeable tape to the top, Breather tape to the foot.
Ensure that the tapes are well bonded to the panels along edges and corners.

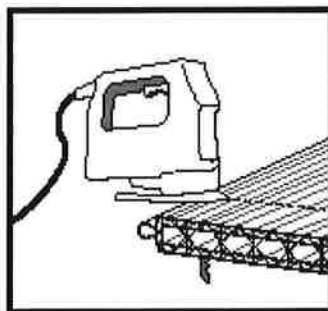

Cut panel to length and blow out swarf.

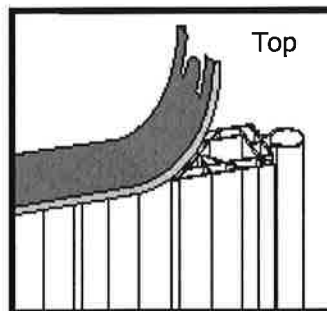

Apply Blanking Tape to top of panel.

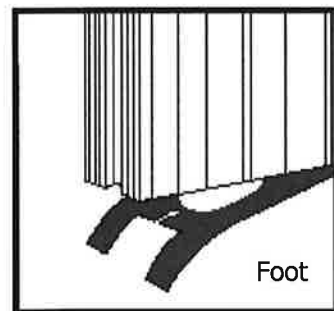

Apply Breather Tape to foot of panel.

INSTALLING THE POLYCARBONATE PANELS (2)

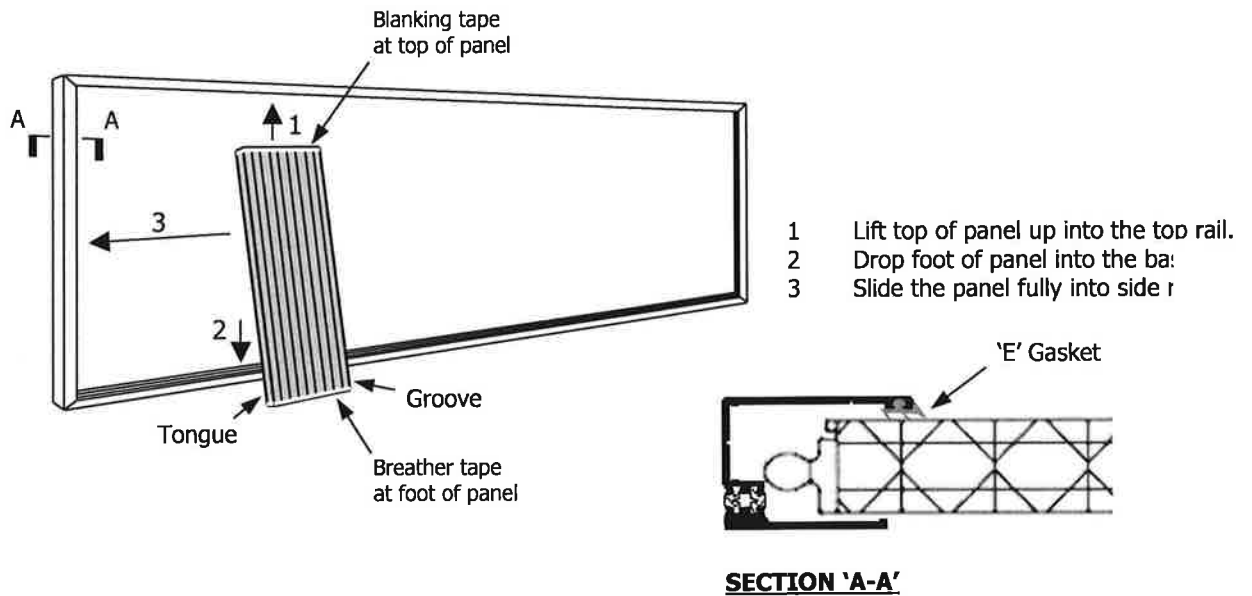

Check if first 500mm wide panel needs to be cut narrower.

METHOD:-

Install first full width panel and slide fully into side rail. Take a check dimension as shown.

Calculate how many full width panels will be needed to complete the area.

Check that Dimension 'X' will be within the tolerances 544mm to 950mm (See page 6).

If not, cut the left hand side of the first panel to adjust Dimension 'X'.

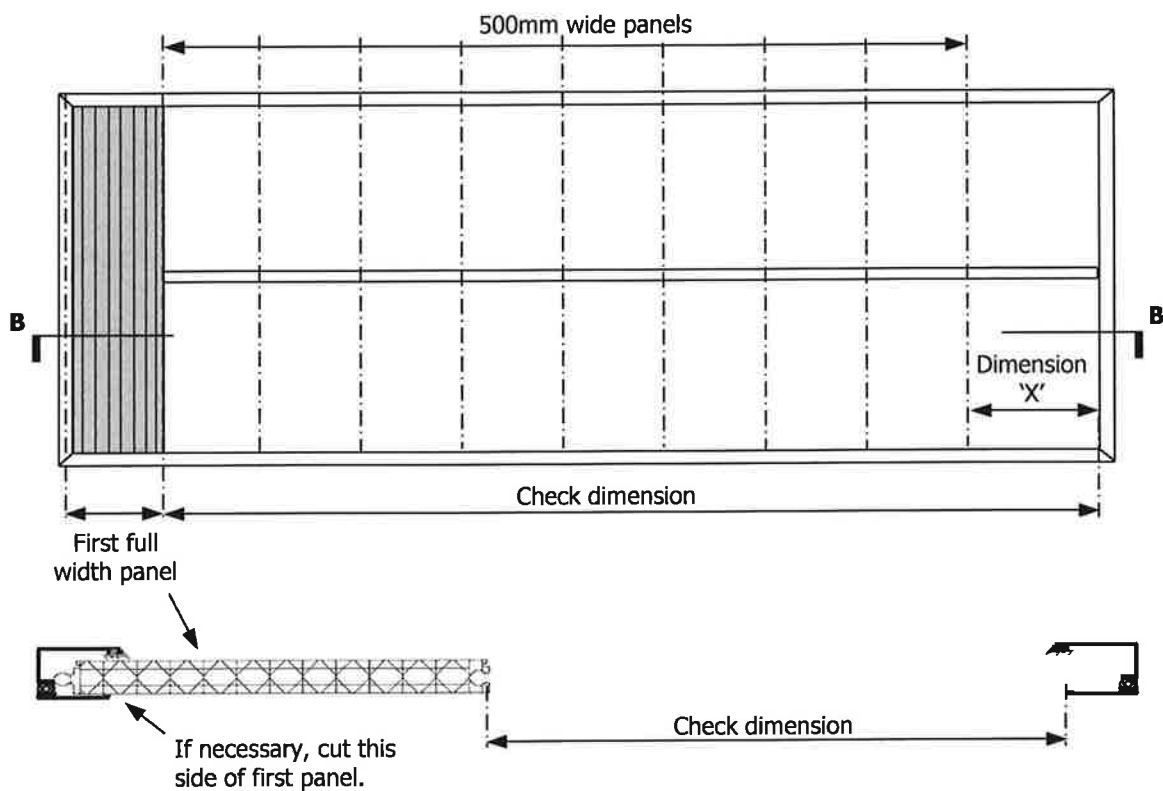

INSTALLING THE POLYCARBONATE PANELS (3)

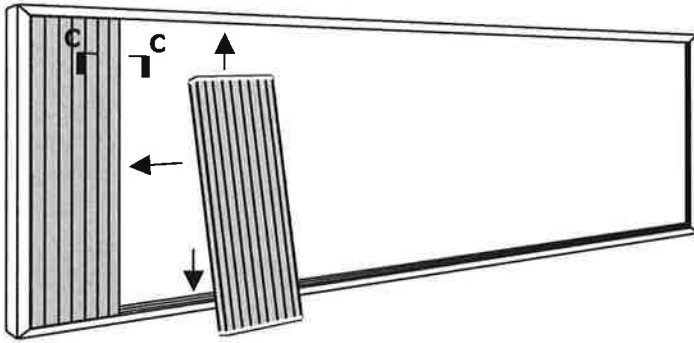

- 4 Install second panel as before and slide firmly until the tongue has clicked onto the groove of the first panel.

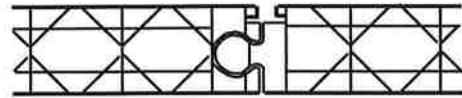

SECTION 'C - C'

NB

If there are intermediate support rails, Fix-Keys must be locked into the joint of each panel junction as the panels are installed. (See page 8 for details).

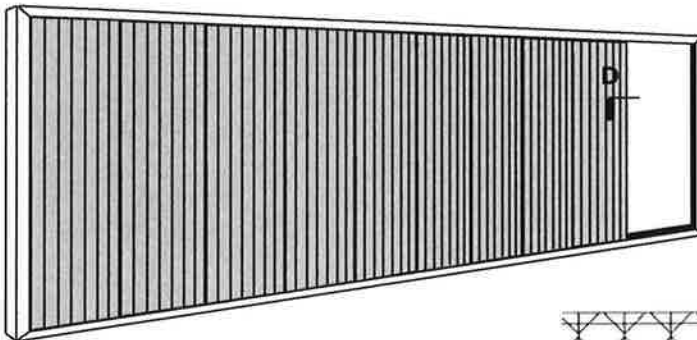

D

NB

Dimension 'X' must be within the tolerances shown i.e. 544mm to 950mm

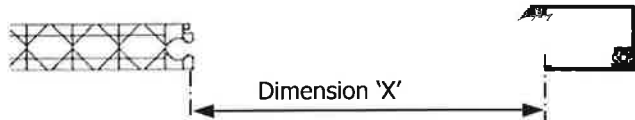

SECTION 'D - D'

Dimension 'X'
Greater than 544mm
and Less than 950mm



INSTALLING THE POLYCARBONATE PANELS (4)

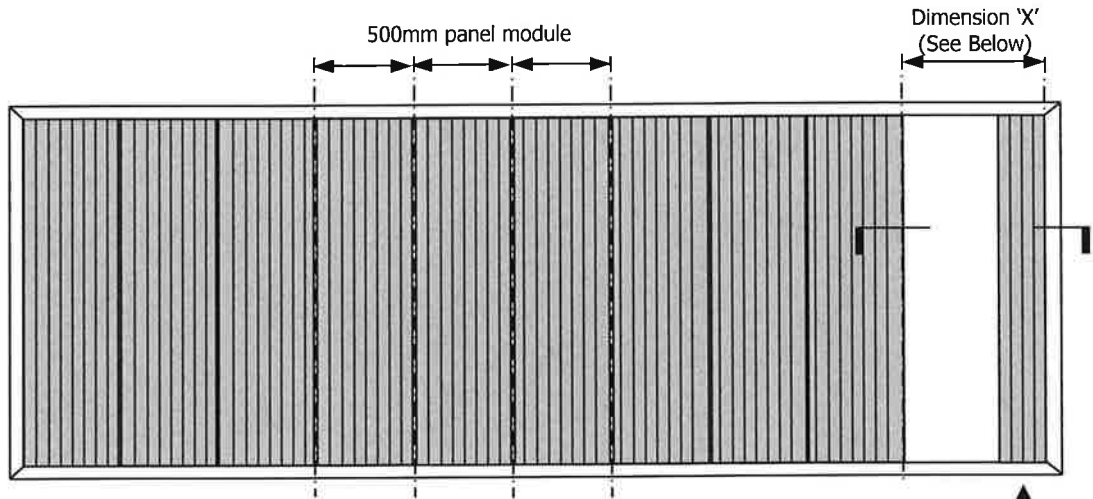

**The width of the last panel is calculated by:-
Dimension 'X' + 50mm - 544mm**

Cut the last panel to the correct width, blow, tape and install into frame following the sequence shown below.

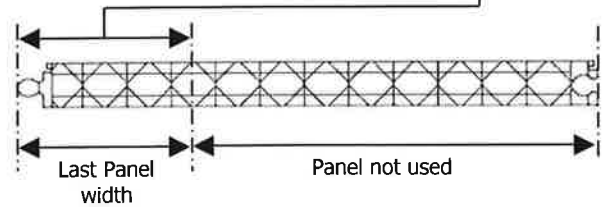

1. Feed one or more 1m lengths of webbing around the last panel, then install it into the frame and push fully to the right into the side rail.

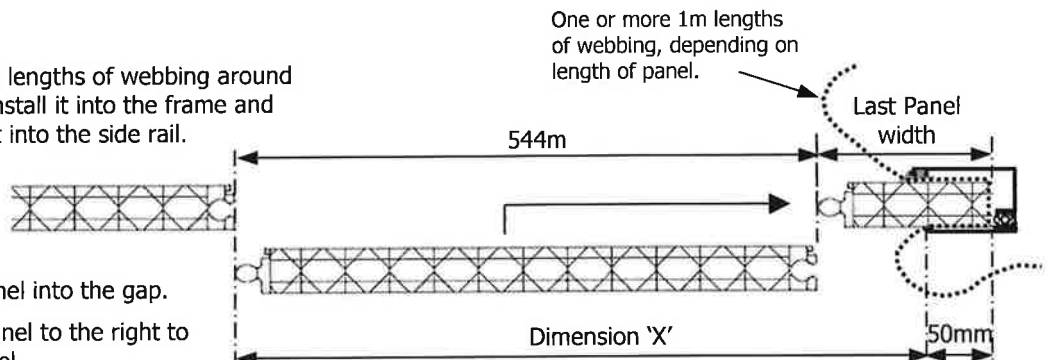

2. Install a full width panel into the gap.
3. Push the full width panel to the right to lock onto the cut panel

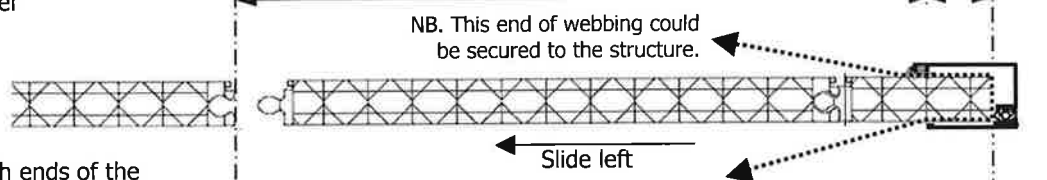

4. Pulling equally on both ends of the webbing, slide the two locked panels to the left until they lock into the previous groove.

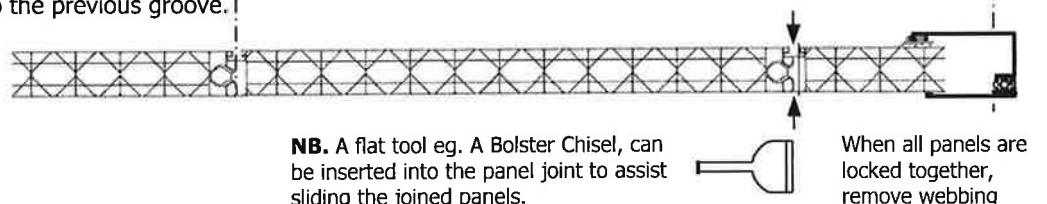

NB

When all the panels have been installed, a wedge gasket is inserted into the frame (See next page).

FIX-KEYS & WEDGE GASKET

INSTALLING FIX-KEYS AT INTERMEDIATE STRUCTURAL SUPPORTS:-

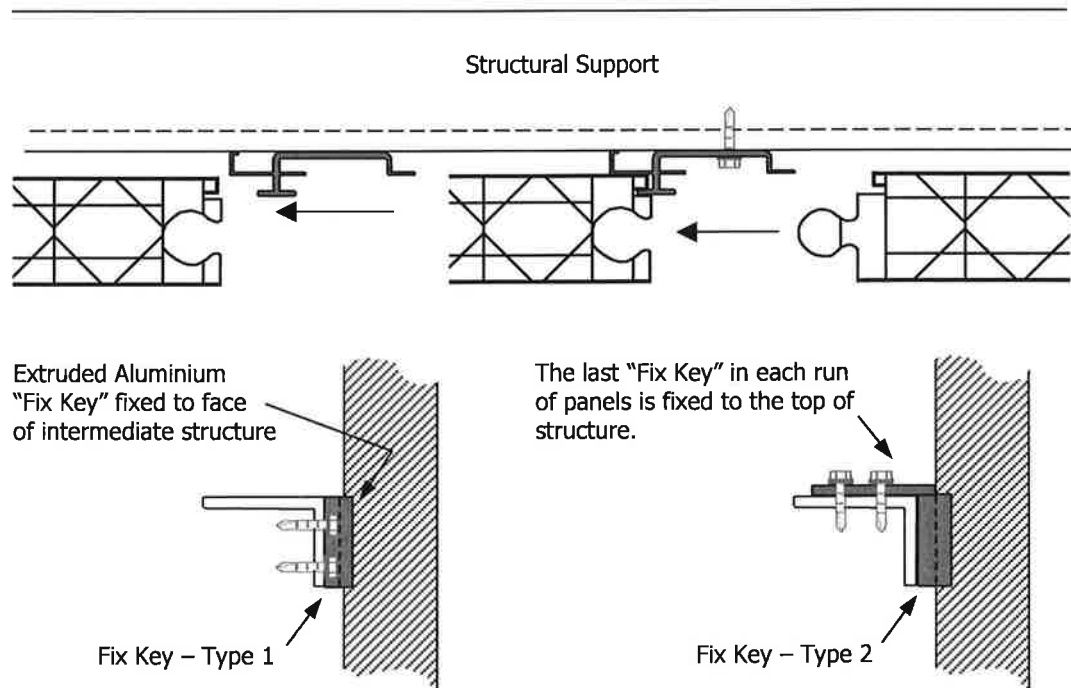

INSTALLING WEDGE GASKET TO COMPLETE THE SYSTEM:-

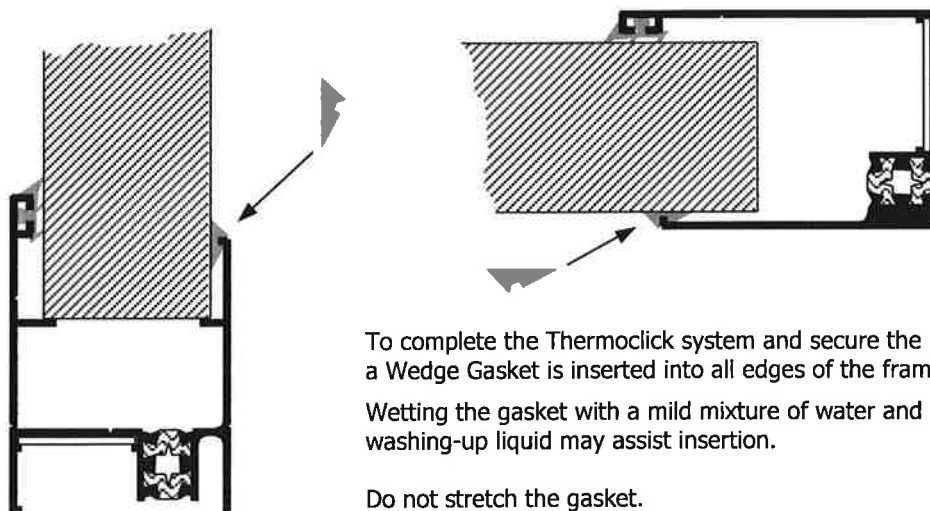

TWINFIX

201 Cavendish Place
Birchwood Park, Birchwood
Warrington, WA3 6WU