

# TWINFIX

## Fixing Instructions for the Twinfix 226/227 Structural Glazing Bar System

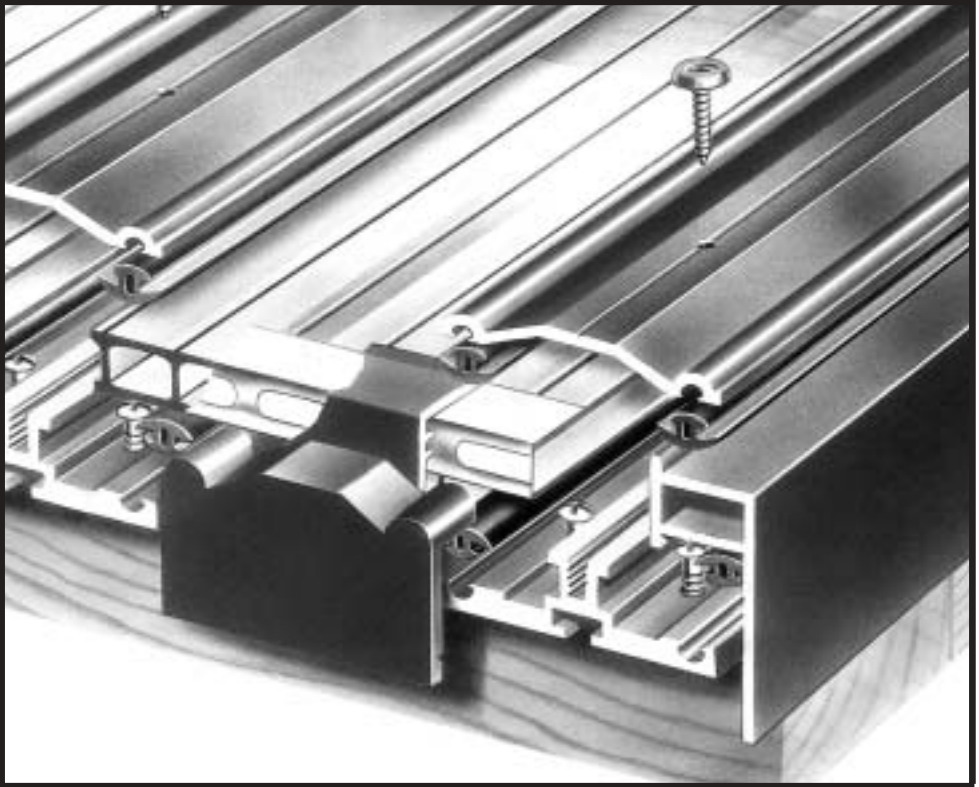

### Tools you will need to construct your Twinfix roof:

Tape Measure  
Screwdriver  
Spirit Level  
Hacksaw  
Drill  
Hammer

Twinwall Fixings (UK) Limited  
201 Cavendish Place  
Birchwood Park  
Risley  
Warrington  
Cheshire WA3 6WU

Tel: 01925 811311  
Fax: 01925 852955  
Email: [enquiries@twinfix.co.uk](mailto:enquiries@twinfix.co.uk)  
Website: [www.twinfix.co.uk](http://www.twinfix.co.uk)

# System Description

The 226/227 System is designed for installing multiwall polycarbonate glazing and will span up to 1500mm unsupported. It consists of an aluminium base bar and a screw on aluminium capping bar which clamps the multiwall glazing firmly and securely in place. A wide range of complementary items, fixing accessories and matching profiles are available.

## Design Detail

Multiwall polycarbonate sheet is normally used on a roof with a gentle slope, which will allow rainwater to drain into guttering. We recommend that the minimum slope should be 5 degrees. The 226/227 System can be used with 10mm, 16mm, 20mm and 25mm sheet.

Sheets of polycarbonate will expand and contract as temperatures change, always leave room to accommodate expansion when joining sheets on glazing bars. Sheet widths should be reduced by approximately 20mm to allow for expansion. For example, if your glazing bars are 1000mm apart (centre to centre), use a 980mm wide sheet.

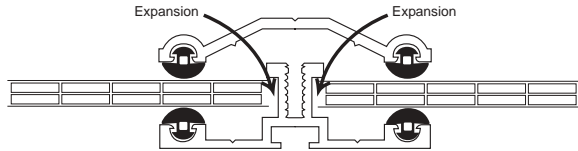

Fig. 1

Sheet Thickness	Glazing Bar Centres	Spans Unsupported
10mm	700mm	1500mm
16mm	1000mm	1500mm
25mm	1200mm	1500mm

When ordering or cutting polycarbonate sheet to required length remember that your sheet should be 10mm shorter than your glazing bars to allow for the fitting of aluminium U profiles. We can supply you with sheet that has been cut to size, blown and sealed in our factory, (in which case disregard steps 6 and 7).

If you need to span more than 1500mm, we strongly advise installing an intermediate purlin support or using the 280 or 600 system. 16mm sheet can be accommodated on glazing bar centres of no more than 1000mm (Fig. 2).

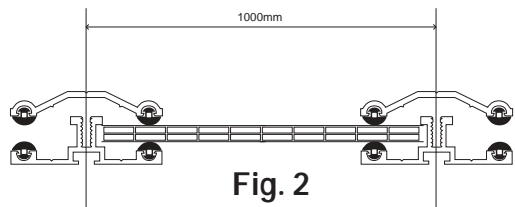
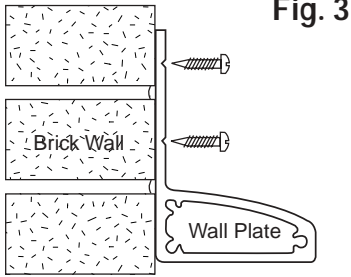

Fig. 2

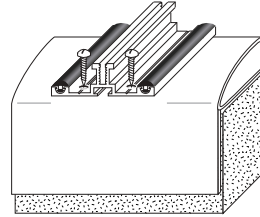

**Fig. 3**

**Step 1:** Fit the aluminium wall plate (Ref. 290). The wall plate can accommodate all Twinfix bar systems at angles ranging from 5 degrees to 25 degrees (Fig. 3). Fix the end plate for a neat finish to the ends of the wall plate.

**Step 2:** Fit the aluminium eaves beam (Ref. 291) to the eaves end of the structure. The eaves beam can accommodate all the Twinfix bar systems at angles ranging from 5 degrees to 25 degrees. Fix the end plate for a neat finish to the ends of the eaves beam.

**Step 3:** Screw the aluminium base bar (Ref. 227) to the eaves beam and wall plate and to any purlins if they are being used, remembering that a glazing bar will be needed at each side of the roof. Slide in the 226 gasket. Please note, if buying the bars in the pre-packs, the gasket is supplied already pressed into the bars (Fig. 4A).



**Fig. 4A**

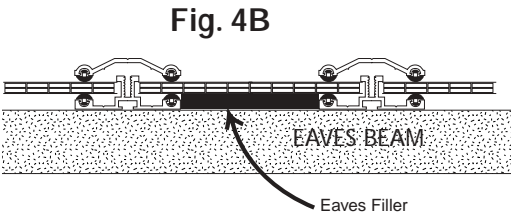
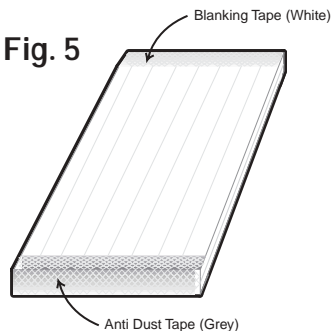

**Fig. 4B**

**Step 4:** Fit eaves filler (Ref. 226F) at the eaves end of the structure. This fills the gap between the underside of the sheet and the top of the support structure (Fig. 4B). If other materials are being used as a wall plate and/or eaves beam, please use barrier tape to avoid electrolyte corrosion between the 226/227 glazing bar and the wall plate and/or eaves beam between the glazing bars.

**Step 5:** Cut the glazing bar cap (Ref. 226) to the required length and pre-drill the cap at regular intervals with holes no more than 400mm apart ensuring that the holes will line up uniformly with the holes on each of the other bars once on the roof. Slide the 226 gasket into each side of the glazing bars. Please note, if buying the bars in pre-pack, the gasket is supplied already pressed into the bars.

**Step 6:** Ensure the sheet is free of any swarf or dirt by blowing air through the flutes and sealing the ridge end of the sheet using blanking tape (Ref. BT 10/25). This permanently closes the ridge end of the sheet and stops further ingress of dirt or moisture (Fig. 5). Sealing the sheet can be done at the factory prior to delivery.



**Fig. 5**

**Step 7:** Seal the eaves (gutter) end of the sheet with anti-dust tape (Ref. ADT 10/25), this closes the eaves end helping to prevent dust entry whilst allowing condensation drainage (Fig. 5). Sealing of the sheet can be done at the factory prior to delivery.

**You can now start to fix the roof sheets; starting at one side of the roof and working across, fixing and dressing down flashings as you go.**

Please Note: Multiwall polycarbonate has protective film on both sides, however only one side is printed. This is the side that should face outwards. Do not forget to remove the masking film on the underside of the sheet.

**Step 8:** Having already fitted a glazing bar base (Ref. 227) to one end of the structure, then fix a side trim (Ref. 272/275) over the glazing bar base to the side of the fascia or building (Fig. 6).

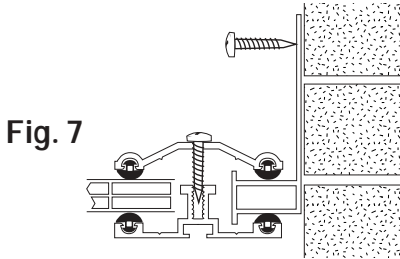
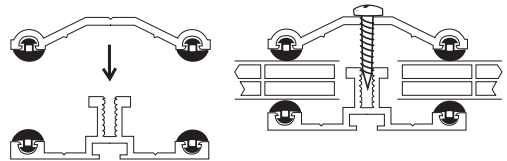

**Fig. 7**

**Step 9:** If butting a sheet up to a wall face, simply upturn the side trim profile (Fig. 7).

**Fig. 8**

**Step 10:** Fix the top U profile (Ref. 252-255) over the sheet. Locate the sheet over the 227 base bar leaving room for expansion. Ensure the sheet is level and then fit the screw down glazing bar cap (Ref. 226) using the recommended screws, capping over with a screw cover cap. (Fig. 8).



**Fig. 9**

**Step 11:** Place an adjoining sheet into position with top U Profile fitted. Repeat this procedure for the remaining panels ensuring that screws are not over tightened as this will limit the expansion and compress the sheet.

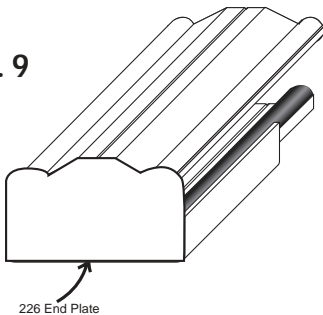

**Step 12:** Push fit the polycarbonate end plate (Ref. 226EP) onto the end of the 226/227 system (Fig. 9).

**Step 13:** Accurately cut the aluminium U profile (Ref. 252/3/5) to the appropriate length and fix over the anti-dust tape at the eaves end of the sheet between the end plates. If you wish a small bead of silicone sealant can be applied to the upper side of the sheet long the line where it meets the U profile and smooth to give a neat finish. Only use silicone sealant that is compatible with multiwall polycarbonate (Fig. 10).

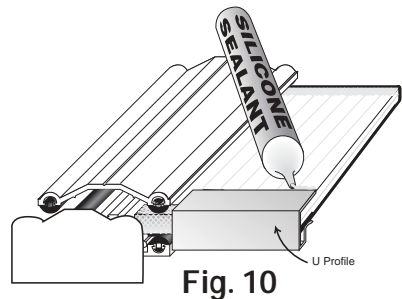

**Fig. 10**

**Step 14:** Final dressing of the Butyl Flashing (Ref. 200/10).