

TWINFIX

Fixing Instructions for the Twinfix 261 Rafter Gasket Glazing System

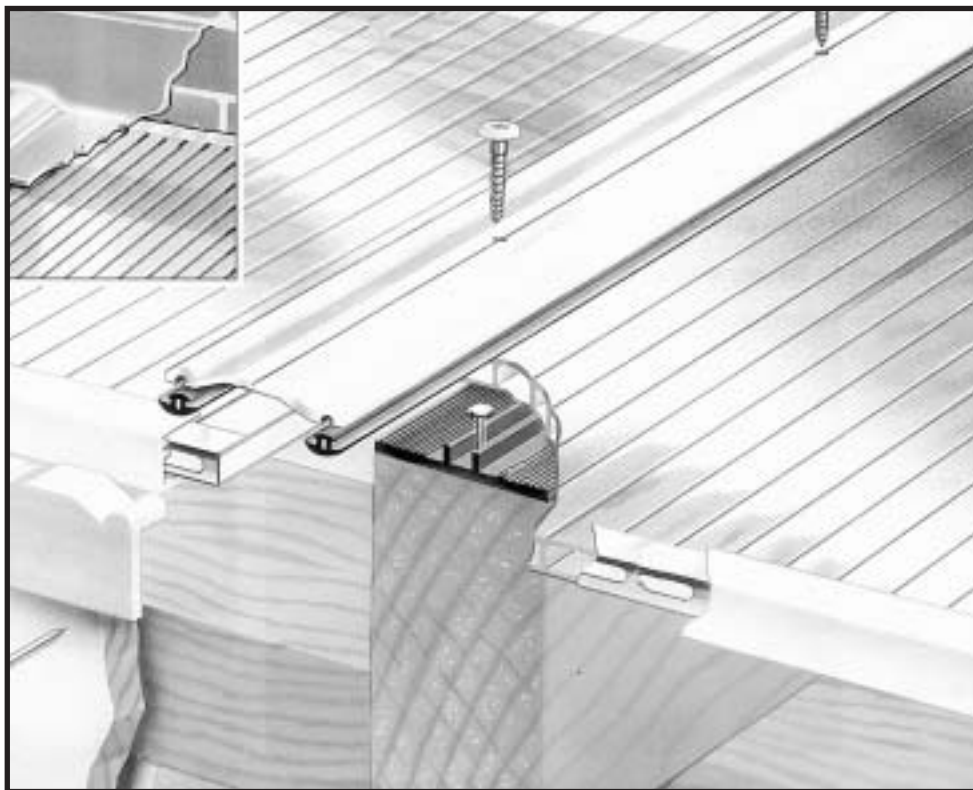

Tools you will need to construct your Twinfix roof:

Tape Measure
Screwdriver
Spirit Level
Hacksaw
Drill
Hammer

Twinwall Fixings (UK) Limited
201 Cavendish Place
Birchwood Park
Risley
Warrington
Cheshire WA3 6WU

Tel: 01925 811311
Fax: 01925 852955
Email: enquiries@twinfix.co.uk
Website: www.twinfix.co.uk

System Description

The 226/261 series is designed for installing multiwall polycarbonate glazing on standard 60mm wide rafters. It consists of a 60mm wide rafter gasket and a screw-on aluminium capping bar, which clamps the multiwall glazing firmly and securely in place. A wide range of other complementary items, fixing accessories and matching profiles are available.

Design Detail

Multiwall polycarbonate sheet is normally used on a roof with a gentle slope, which will allow rainwater to drain into gutters. We recommend that the minimum slope should be 5°. The 226/261 system can be used with 10mm, 16mm, 20mm and 25mm sheet.

Sheets of polycarbonate have a tendency to expand and contract as temperatures change, always leave room to accommodate expansion when joining sheets on glazing bars. Sheet widths should be reduced by approximately 20mm to allow for expansion. For example; if your glazing bars are 1000mm apart (centre to centre), use a 980mm wide sheet.

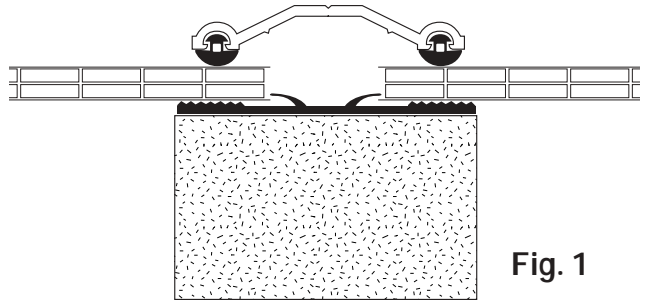

Fig. 1

Sheet Thickness	Glazing Bar Centres
10mm	700mm
16mm	1000mm
25mm	1250mm

When ordering or cutting polycarbonate sheet to length, remember that your sheet should be 10mm shorter than your glazing bars to allow for the fitting of aluminium 'U' profiles. We can supply you with sheet that has been cut to size, blown and sealed in our factory (in which case disregard steps 5 and 6 on the next page).

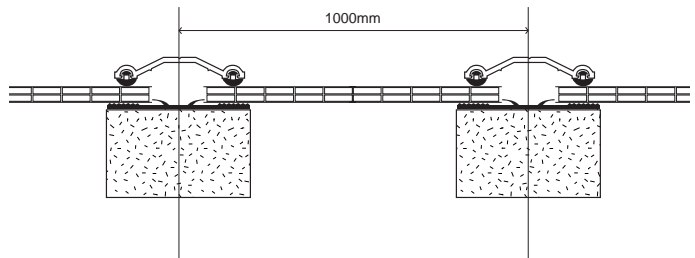

Fig. 2

Step 1: Measure and set out where the rafters and if they are going to be used, purlins are going to lie. 60mm wide rafters are normal when using the 226/261 system. 16mm sheet can be accommodated on centres no more than 1000mm apart (Fig. 2), whereas the glazing centres for 25mm sheet can be extended to 1250mm. If 50mm wide rafters are already in place, you must pin a 5mm or 6mm quadrant to each side of the rafter, so turning it into a 60mm rafter. (Fig. 3) or alternatively use the 227 aluminium base or the 500 system if glazing with 10mm twinwall polycarbonate.

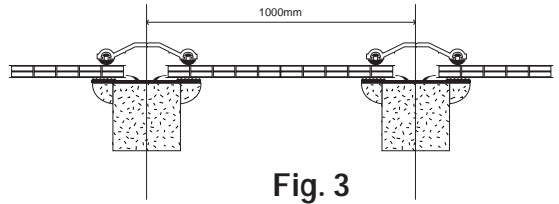

Fig. 3

Step 2: Nail the rafter gasket (Ref. 261) to the rafters through the centre channel with nails at 300mm apart. Please note, only galvanised nails should be used.

Step 3: Fix the eaves filler (Ref. P226F) across the structure at the eaves end (Fig. 4). This solves the problem of filling the gap between the underside of the sheet and the top of the support structure.

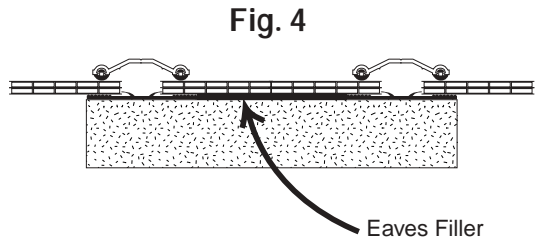

Fig. 4

Step 4: Cut the glazing bar cap (Ref. 226) to the required length and pre-drill the cap at regular intervals with holes no more than 400mm apart ensuring that the holes will line up uniformly with the holes on each of the other bars once on the roof. Slide the 226 gasket into each side of the glazing bars. (Please note, if buying the bars in pre-packs, the gasket is supplied already pressed into the bars).

Step 5: Ensure the sheet is free of any swarf or dirt by blowing air through the flutes and sealing the ridge end of the sheet using blanking tape (Ref. BT10/25). This permanently closes the ridge end of the sheet stopping any further ingress of dirt or moisture (Fig. 5). Sealing of the sheet can be done at the factory prior to delivery.

Step 6: Seal the eaves (gutter) end of the sheet with anti-dust tape (Ref. ADT10/25), this closes the eaves end helping to prevent dust entry whilst allowing condensation drainage (Fig. 5). Sealing of the sheet can be done at the factory prior to delivery.

Fig. 5

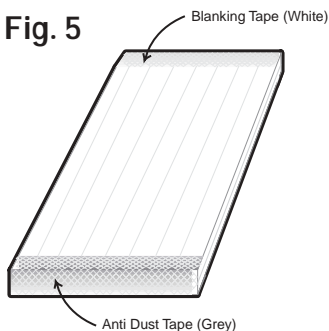

You can now start to fix the roof sheets; starting at one side of the roof and working across, fixing and dressing down flashings as you go.

Please note, multiwall polycarbonate has protective film on both sides. However, only one side is printed. This is the side that should face outwards. Do not forget to remove the masking film on the underside of the sheet.

Step 7: End panel first, prior to putting the sheet on the roof, we suggest you gently tap the 'F' profile (Ref. 222/223/225) onto the sheet whilst it is stood on its edge, remembering to leave 5mm for width expansion. Then fit the top 'U' profile (Ref. 252/253/255) over the sheet between where the rafters sit. At the eaves end, we suggest you cut away the two arms of the 'F' profile by approximately 20mm. This will allow the flat leg of the 'F' to butt up to the 'U' profile when fitting the 'U' later. Place in position ensuring the sheet is level and then screw fix through the 'F' profile to the side of the fascia or building (Fig. 6).

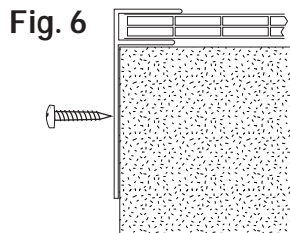
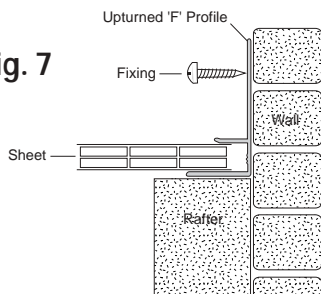

Fig. 7



Step 8: If butting up to a wall face, simply upturn the 'F' profile (Fig. 7).

Step 9: Place an adjoining sheet with 'U' profile already fitted at the ridge end into position on the rafter gasket remembering to leave 5mm at either side for expansion. Fix through the 226 cap and through the 261 gasket by using 62mm stainless steel wood screws (Ref. 62/10/WS). Ensure that screws are not over tightened as this will undulate the glazing bar cap, limit

the expansion and compress the sheet (Fig. 8). Finally press down the screw cover caps.

Step 10: Repeat this procedure for the remaining panels and on the last panel, repeat step 7 or 8 to finish off.

Fig. 8

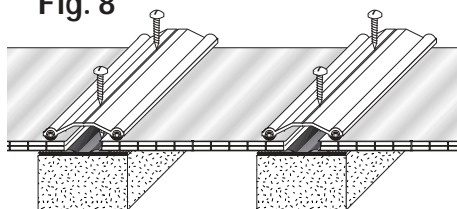

Step 11: Push fit the polycarbonate end plate (Ref. 226EP) onto the end of the 226 glazing bars to give a neat finish (Fig. 9).

Step 12: Measure and accurately cut the

Fig. 9

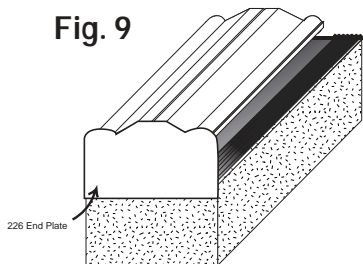

aluminium 'U' profile (Ref. 252/253/255) to the exact length and fix over the anti-dust tape at the eaves end of the sheet between the end plates. A small bead of silicone sealant can be applied to the upper side of the sheet along the line where it meets the 'U' profile and smooth to give a neat finish (Fig. 10) Only use silicone sealant that is

compatible with multiwall polycarbonate.

Step 13: Finally dress down the Butyl Flashing (Ref. 200/10).

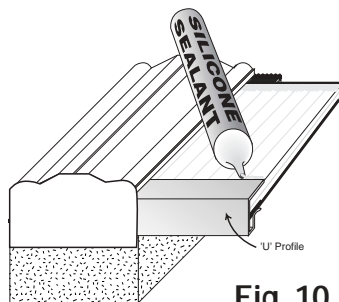

Fig. 10

As our policy is one of continuous improvement, we reserve the right to change specifications without prior notice. All information, recommendations or advice (written or verbal) provided by Twinfix is given in good faith and to the best of our knowledge.