

TWINFIX

Fixing Instructions for the Twinfix 500 Rafter Gasket Glazing System

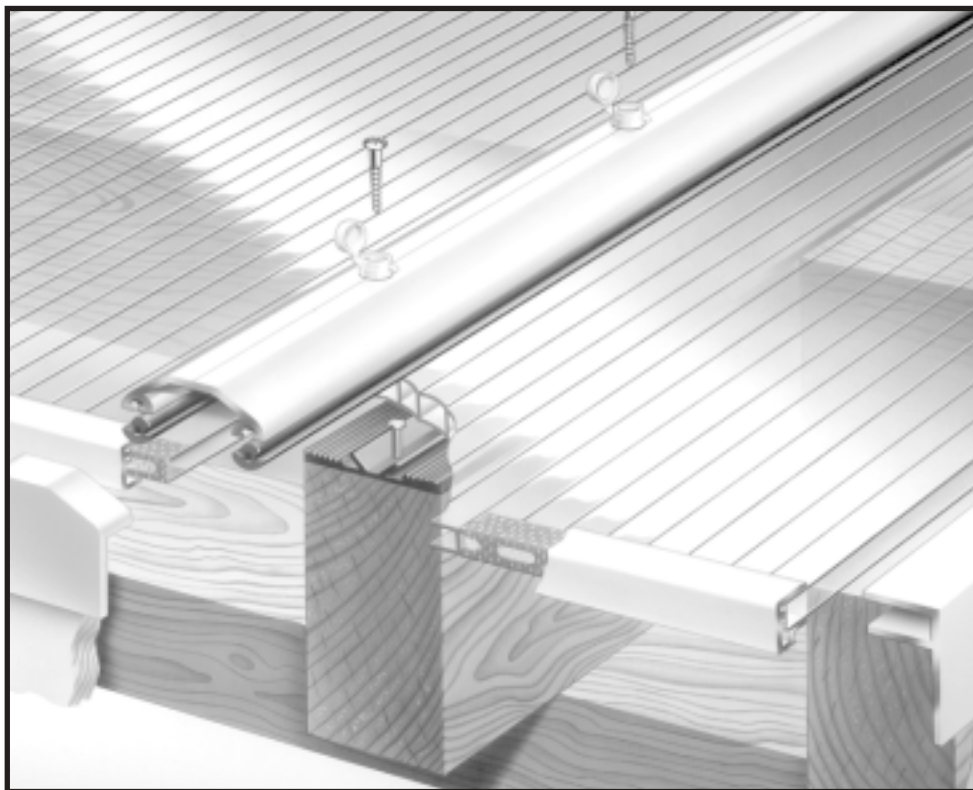

Tools you will need to construct your Twinfix roof:

Tape Measure
Screwdriver
Spirit Level
Hacksaw
Drill
Hammer

Twinwall Fixings (UK) Limited
201 Cavendish Place
Birchwood Park
Risley
Warrington
Cheshire WA3 6WU

Tel: 01925 811311
Fax: 01925 852955
Email: enquiries@twinfix.co.uk
Website: www.twinfix.co.uk

System Description

The 500/501 series is designed for installing multiwall polycarbonate glazing on standard 50mm wide rafters. It consists of a 50mm wide rafter gasket and a screw-on aluminium capping bar, which clamps the multiwall glazing firmly and securely in place. A wide range of other complementary items, fixing accessories and matching profiles are available. The 500 system is normally used when working with 10mm twinwall sheet. Care must be taken if using 16mm, we recommend only ever using 980mm block edge sheet in the 16mm thickness. Failure to do this could result in sheet popping out in high winds or heavy snow loads.

Design Detail

Multiwall polycarbonate sheet is normally used on a roof with a gentle slope, which will allow rainwater to drain into guttering. We recommend that the minimum slope should be 5°.

Sheets of polycarbonate will expand and contract as temperatures change, always leave room to accommodate expansion when joining sheets on glazing bars. Sheet widths should be reduced by approximately 20mm to allow for expansion and the central element of the rafter gasket. For example; if the distance between the centre of your rafters is 700mm, use sheets cut to 680mm wide.

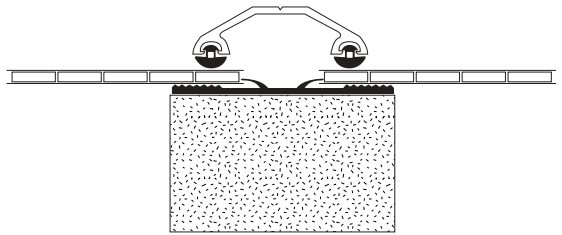

Fig. 1

Sheet Thickness	Glazing Bar Centres
10mm	700mm

When ordering or cutting polycarbonate sheet to required length remember that your sheet should be 10mm shorter than your glazing bars to allow for aluminium 'U' profiles. We can supply you with sheet that has been cut to size, blown free of dust and sealed in our factory in which case disregard steps 5 and 6 on the next page.

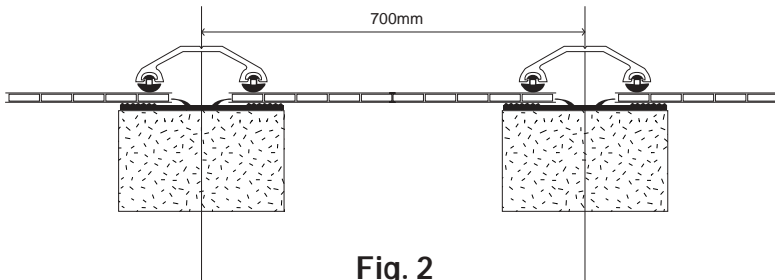

Fig. 2

Step 1: Measure and set out where the rafters and, if they are going to be used, purlins, are going to lie. 50mm wide rafters are normal when using the 500/501 system. 10mm sheet can be accommodated at maximum glazing centres of 700mm (Fig. 2).

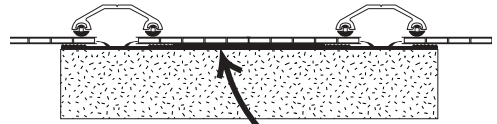

Fig. 3 Eaves Filler

Step 2: Nail the rafter gasket (Ref. 501) to the rafters through the centre channel with nails at 300mm apart. Please note only galvanised nails must be used.

Step 3: At the same time, fix the eaves filler (Ref. 226F) across the structure at the eaves end (Fig. 3). This solves the problem of filling the gap between the underside of the sheet and the top of the support structure.

Step 4: Cut the glazing bar caps (Ref. 500) to the required length and pre-drill the caps at regular intervals with holes no more than 400mm apart, ensuring that the holes line up uniformly with the holes on each of the other bars once on the roof. Slide the gasket (Ref. 226G) into each side of the glazing bar. Please note, if buying the bars in pre-packs, then the gasket is supplied already pressed into the bars.

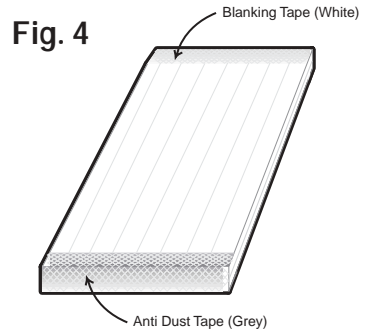

Fig. 4

Step 5: Ensure the sheet is free of any swarf or dust by blowing air through the flutes and seal the ridge end of the sheet using blanking tape (Ref. BT10). This permanently closes the ridge end of the sheet stopping any further ingress of dirt or moisture (Fig. 4). Sealing of the sheet can be done at the factory prior to delivery.

Step 6: Seal the eaves (gutter) end of the sheet with anti-dust tape (Ref. ADT10), this closes the eaves end helping to prevent dust entry whilst allowing condensation drainage (Fig. 4). Sealing of the sheet can be done at the factory prior to delivery.

You can now start to fix the roof sheets; starting at one side of the roof and working across, fixing and dressing down flashings as you go.

Please note: Multiwall polycarbonate has protective film on both sides however only one side is printed, this is the side that should face outwards. Do not forget to remove the masking film on the underside of the sheet.

Step 7: End panel first, prior to putting the sheet onto the roof, we suggest you gently tap the 'F' profile (Ref. 222), onto the sheet whilst it is stood on its edge remembering to leave 5mm for width expansion. Then fit the top 'U' profile (Ref. 252), over the sheet between where the rafters sit. At the eaves end, we suggest you cut away the two arms of the 'F' profile by approximately 20mm. This will allow the flat leg of the 'F' to butt up to the 'U' profile when fitting the 'U' later. Place in position,

Fig. 5

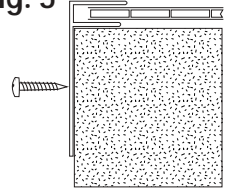

ensuring the sheet is level and then screw fix through the 'F' profile to the side of the fascia or building (Fig. 5).

Fig. 6

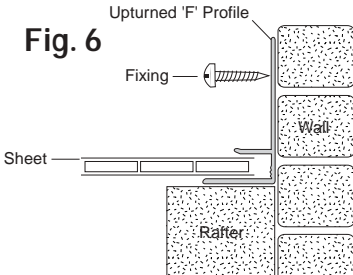

Step 8: If butting up to a wall face, simply upturn the 'F' profile (Fig. 6).

Step 9: Place an adjoining sheet with 'U' profile already fitted at the ridge end into position on the rafter gasket remembering to leave 5mm at either side for

expansion. Fix through the 500 cap and through the 501 gasket by using 62mm stainless steel wood screws (Ref. 62/10/VWS). Ensure that the screws are not over tightened as this will undulate the glazing bar cap, limit the expansion and compress the sheet (Fig. 7). Finally press down the screw cover caps.

Fig. 7

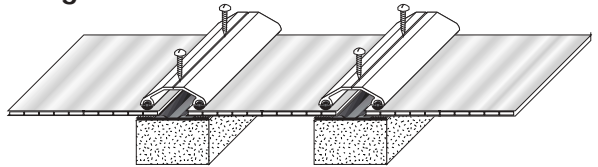
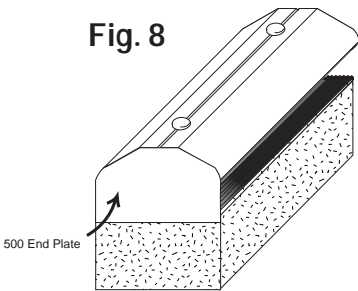

Fig. 8



Step 10: Repeat this procedure for the remaining panels and on the last panel, repeat step 7 or 8 to finish off.

Step 11: Push fit the polycarbonate end plate (Ref. 500EP) onto the ends of the 500 glazing bars to give a neat finish (Fig. 8).

accurately cut the aluminium 'U' profile (Ref. 252) to the exact length and fix over the anti-dust tape at the eaves end of the sheet between the end plates. A small bead of silicone sealant can be applied to the upper side of the sheet along the line where it meets the 'U' profile and smooth to give a neat finish (Fig. 9). Only use silicone sealant compatible with multiwall polycarbonate.

Step 12:

Measure and

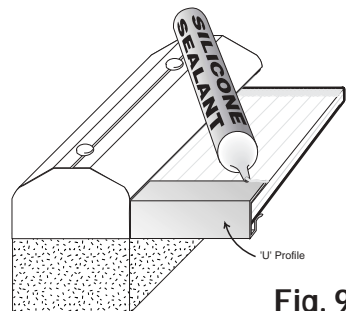

Fig. 9

Step 13: Finally dress down the Butyl Flashing (Ref. 200/10).